

14SFHK SERIES SPIN-OUT FILTER/SEPARATOR HOUSINGS & KITS

Spin-out filtration is a method of removing sediment from water using centrifugal force rather than filter media. As water enters the unit, it is directed into a spinning motion that forces heavier particles, such as sand and grit outward to the wall of the filter bowl, where they settle into a collection chamber for easy purging.

Spin-out filters are primarily used as pre-filters to remove coarse sediment ahead of finer filtration systems. By capturing larger debris, they help prevent downstream (finishing) filters from clogging, which extends cartridge life, reducing maintenance, and improving overall system performance. While they are most commonly used in rural water well systems, as well as agricultural and irrigation applications, they are often used in other commercial and industrial applications where particulate needs to be removed from the fluid media.

These filters are rated by mesh size, which defines the size of particles they remove. The higher the mesh rating, the finer the particulate removed.

Unlike traditional filters, spin-out filters create minimal pressure loss, making them the only type of filter suitable for installation on the suction side of a pump without restricting flow or causing cavitation.

Proper sizing is critical to performance. Spin-out filters rely on adequate water velocity to create the spinning action required for separation. Selecting a unit with a higher GPM rating than necessary or oversizing the filter can reduce this effect, resulting in decreased sediment removal efficiency. **DO NOT OVERSIZE!** Make sure to size the filter within the optimal flow rate. 1" (5-23 GPM), 1-1/2" (23-45 GPM), 2" (45-100 GPM).

NOTE: Filtration performance may vary depending on flow rate, particle size, sediment concentration, and system conditions.

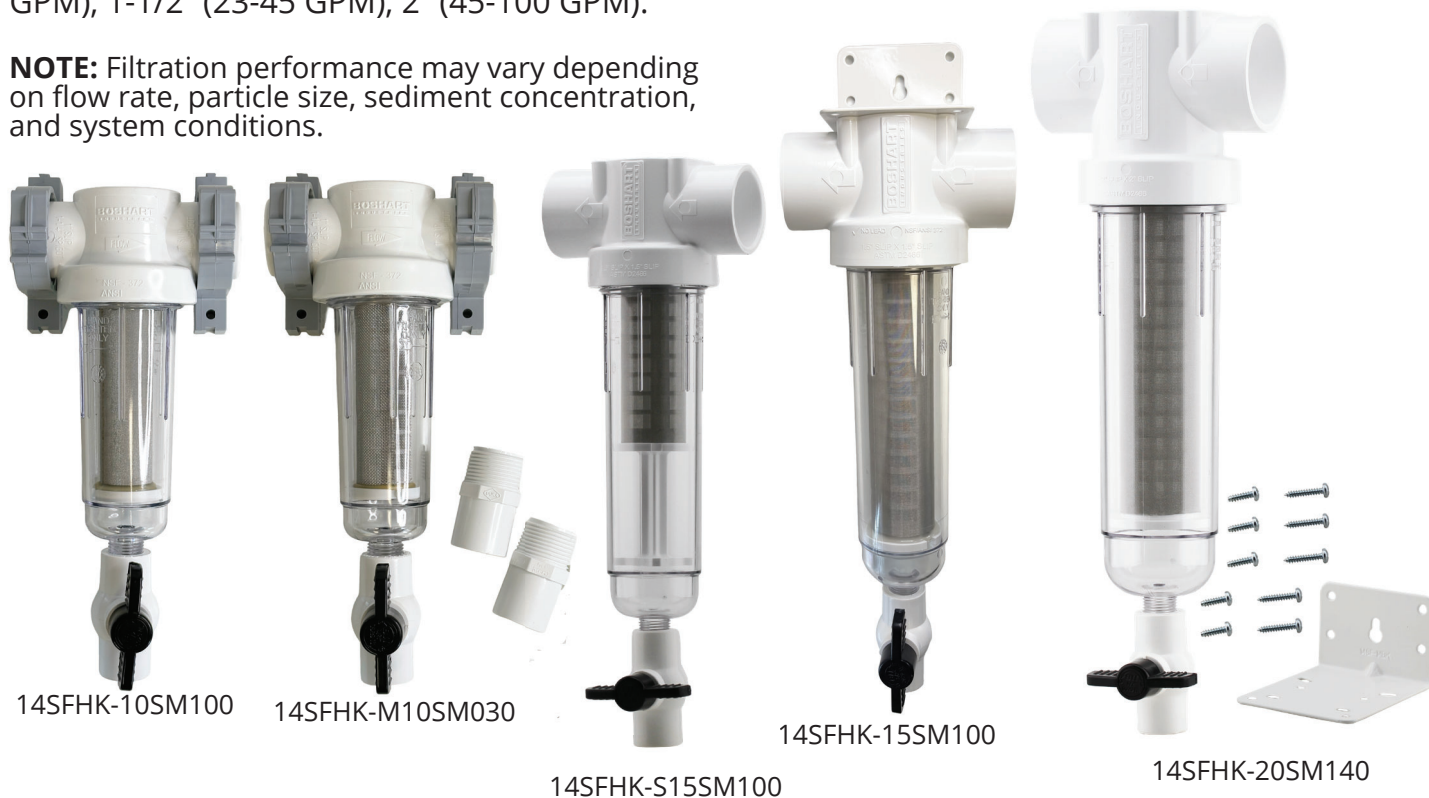

User Responsibility Statement: It is the user's sole responsibility to determine the product's suitability for its intended use. For full details, visit Boshart Industries [Reference Documents](#) for our User Safety Responsibility Statement and other important documents.



25 Whaley Avenue, PO Box 310, Milverton, ON CANADA N0K 1M0
Tel: 800-561-3164

VISIT US ONLINE AT BOSHART.COM

For more information on installation, adjustment, repair & operation, visit Boshart Knowledge Base at SUPPORT.BOSHART.COM

14SFHK-(S)15 SERIES 1-1/2" SPIN-OUT FILTER/SEPARATOR HOUSINGS & KITS

APPLICATION:

- Water Well and Municipal Water Supplies
- Agriculture
- Industrial / Commercial / Residential
- Irrigation

FEATURES:

- Compatible with Schedule 40 & 80 PVC Pipe
- Gripper Ribs on Filter Bowl
 - No tools Required to install / remove filter bowl
- Flush System - 1/2" MPT Connection for Purge Valve
- Suitable for Installation on either the Suction or Pressure Side of Pump
- Elements marked with mesh rating and replacement O-Ring for easy identification

LEAD FREE

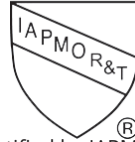

Certified by IAPMO R&T Against NSF/ANSI Standard 372 For Lead Free Compliance.

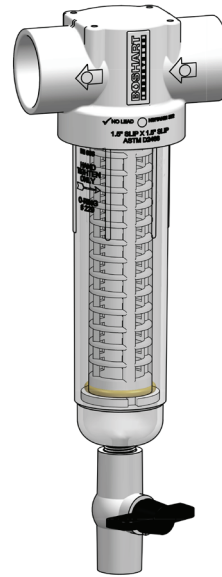

Filter

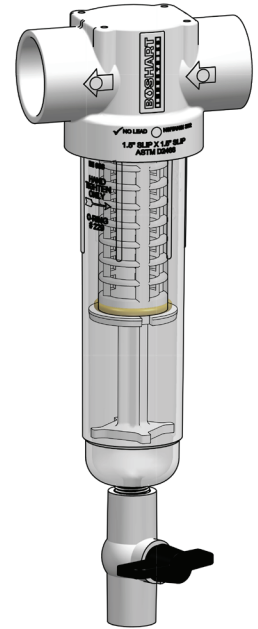

Separator

SPECIFICATION:

- Inlet/Outlet Connection 1-1/2" Slip: ASTM D2466
- Threaded Connections: ASME/ANSI B1.20.1
- Filter Head Materials: ASTM D1784 - Grade 1 PVC
- Maximum Pressure Rating: 150 PSI @ 73°F (23°C)
- Maximum Temperature Rating: 100°F (38°C) @ 40 PSI
- Flow Rate: 10-50 GPM (Optimal Performance: 23-45 GPM)

KIT INCLUDES:

- Housing
- Purge Valve
- Filter or Separator Element (not included in basic unit 14SFHK-15)
- Mounting Bracket and hardware

CERTIFICATION:

- NSF/ANSI Standard 372 Certified (Drinking Water System Components - Lead Content)

Pressure drop will be greater on a system operating at higher flow rates due to increased fluid velocity and friction losses across the separator.

MATERIAL LIST	
Part Name	Material
Head	HR-5009 Rigid Polyvinyl Chloride (PVX) (White)
Bowl	Polycarbonate Lexan 124R
Bowl O-Ring	Nitrile Butadiene Rubber (NBR)
Element Core	HR-5009 Rigid Polyvinyl Chloride (PVC) (White)
Element O-Ring	Nitrile Butadiene Rubber (NBR)
Screen	316 Stainless Steel
Purge Valve	Body: Polyvinyl Chloride (PVC) Handle: Acrylonitrile Butadiene Styrene (ABS) Seat: Thermoplastic Elastomer (TPE)
Mounting Bracket	Powder Coated Steel

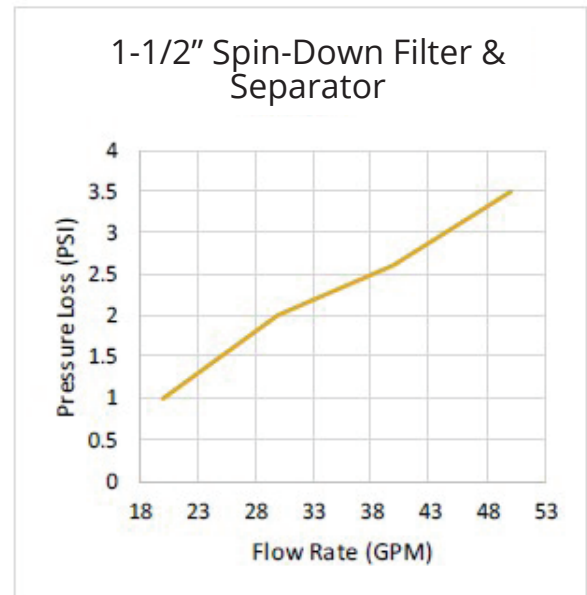

25 Whaley Avenue, PO Box 310, Milverton, ON CANADA N0K 1M0
Tel: 800-561-3164

VISIT US ONLINE AT BOSHART.COM

For more information on installation, adjustment, repair & operation, visit Boshart Knowledge Base at SUPPORT.BOSHART.COM



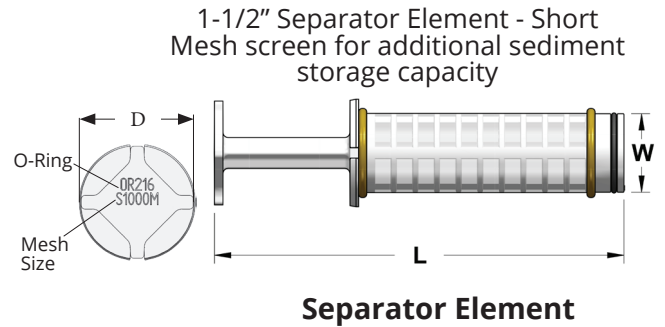
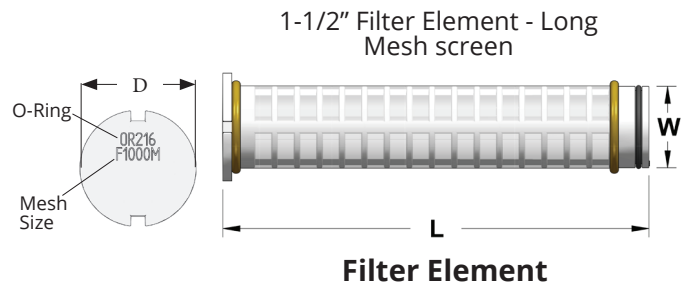
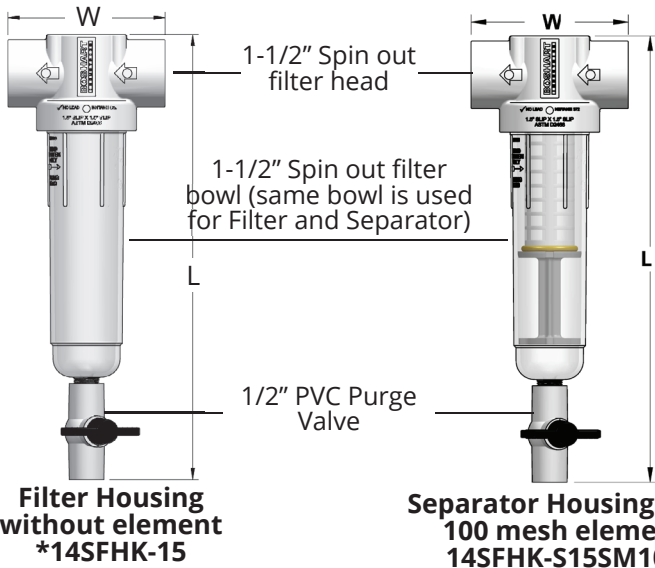

DIMENSIONS

Part No.	Filter Element			Complete Unit with Valve				Filter Element Only				Weight	
	Mesh Size	Micron	Opening	W		L		W		L		lbs	grams
				in	mm	in	mm	in	mm	in	mm		
FILTER HOUSING ONLY (No Element)													
*14SFHK-15	Basic Unit			5.30	134.6	15.07	382.8	—	—	—	—	1.46	662
SEDIMENT FILTER KIT (Housing & Element)													
14SFHK-15SM024	24	711	0.0280	5.30	134.6	15.07	382.8	1.67	42.4	8.14	206.8	1.70	773
14SFHK-15SM030	30	533	0.0232										
14SFHK-15SM040	40	381	0.0165										
14SFHK-15SM060	60	254	0.0100										
14SFHK-15SM100	100	152	0.0060										
14SFHK-15SM140	140	104	0.0040										
14SFHK-15SM200	200	74	0.0029										
14SFHK-15SM250	250	61	0.0024										
14SFHK-15SM500	500	30	0.0012										
14SFHK-15SM1000	1000	15	0.0006										
SEDIMENT SEPARATOR KIT (Housing & Element)													
14SFHK-S15SM024	24	711	0.0280	5.30	134.6	15.07	382.8	1.67	42.4	8.14	206.8	1.65	749
14SFHK-S15SM030	30	533	0.0232										
14SFHK-S15SM040	40	381	0.0165										
14SFHK-S15SM060	60	254	0.0100										
14SFHK-S15SM100	100	152	0.0060										
14SFHK-S15SM140	140	104	0.0040										
14SFHK-S15SM200	200	74	0.0029										
14SFHK-S15SM250	250	61	0.0024										
14SFHK-S15SM500	500	30	0.0012										
14SFHK-S15SM1000	1000	15	0.0006										



25 Whaley Avenue, PO Box 310, Milverton, ON CANADA N0K 1M0
Tel: 800-561-3164

VISIT US ONLINE AT BOSHART.COM

For more information on installation, adjustment, repair & operation, visit Boshart Knowledge Base at SUPPORT.BOSHART.COM



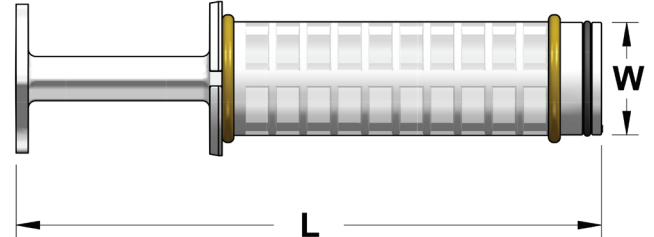
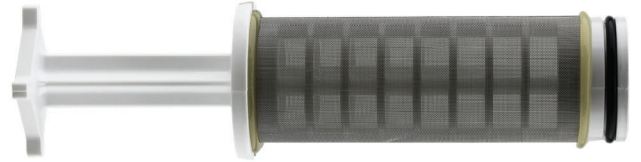
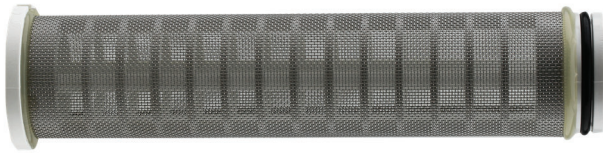
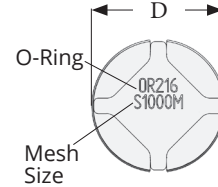
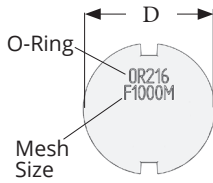

Filter Element

Separator Element

1-1/2" Filter/Seperator Elements

DIMENSIONS										
Part No.	Flow Rate	Mesh Size	Micron Rating	Opening Size	W		L		Weight	
					in	mm	in	mm	lbs	grams
1-1/2" FILTER ELEMENT										
14SF-FE15SM024	10-50 GPM	24	711	0.0280	1.67	42.4	8.14	206.8	1.70	773
14SF-FE15SM030		30	533	0.0232	1.67	42.4	8.14	206.8	1.70	773
14SF-FE15SM040		40	381	0.0165	1.67	42.4	8.14	206.8	1.70	773
14SF-15SM060		60	254	0.0100	1.67	42.4	8.14	206.8	1.70	773
14SF-FE15SM100		100	152	0.0060	1.67	42.4	8.14	206.8	1.70	773
14SF-FE15SM140		140	104	0.0040	1.67	42.4	8.14	206.8	1.70	773
14SF-FE15SM200		200	74	0.0029	1.67	42.4	8.14	206.8	1.70	773
14SF-FE15SM250		250	61	0.0024	1.67	42.4	8.14	206.8	1.70	773
14SF-FE15SM500		500	30	0.0012	1.67	42.4	8.14	206.8	1.70	773
14SF-FE15SM1000		1000	15	0.0006	1.67	42.4	8.14	206.8	1.70	773
1-1/2" SEPARATOR ELEMENT										
14SF-SE15SM024	10-50 GPM	24	711	0.0280	1.67	42.4	8.14	206.8	1.65	749
14SF-SE15SM030		30	533	0.0232	1.67	42.4	8.14	206.8	1.65	749
14SF-SE15SM040		40	381	0.0165	1.67	42.4	8.14	206.8	1.65	749
14SF-SE15SM060		60	254	0.0100	1.67	42.4	8.14	206.8	1.65	749
14SF-SE15SM100		100	152	0.0060	1.67	42.4	8.14	206.8	1.65	749
14SF-SE15SM140		140	104	0.0040	1.67	42.4	8.14	206.8	1.65	749
14SF-SE15SM200		200	74	0.0029	1.67	42.4	8.14	206.8	1.65	749
14SF-SE15SM250		250	61	0.0024	1.67	42.4	8.14	206.8	1.65	749
14SF-SE15SM500		500	30	0.0012	1.67	42.4	8.14	206.8	1.65	749
14SF-SE15SM1000		1000	15	0.0006	1.67	42.4	8.14	206.8	1.65	749



25 Whaley Avenue, PO Box 310, Milverton, ON CANADA N0K 1M0
Tel: 800-561-3164

VISIT US ONLINE AT BOSHART.COM

For more information on installation, adjustment, repair & operation, visit Boshart Knowledge Base at SUPPORT.BOSHART.COM



REPLACEMENT PARTS & ACCESSORIES:

Filter Bowl

Part No.	Description	L		D	
		in	mm	in	mm
14SF-FB10	For 1" filter	6.70	170.18	2.51	63.75
14SF-FB10XS	For 1" separator	9.35	237.49	2.51	63.75
14SF-FB15	For 1-1/2" filter & separator	9.97	253.24	2.83	71.88
14SF-FB20	For 2" filter & separator	11.15	283.21	3.41	86.61

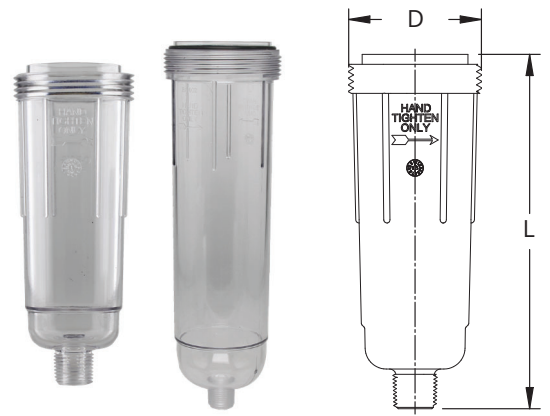

Filter Head

Part No.	Description	D		H	
		in	mm	in	mm
14SF-FH10-BII	For 1" filter and separator	3.12	79.25	2.42	61.47
14SF-FH15-BII	For 1-1/2" filter & separator	3.38	85.85	3.25	82.55
14SF-FH20-BII	For 2" filter & separator	3.98	101.09	4.66	118.36

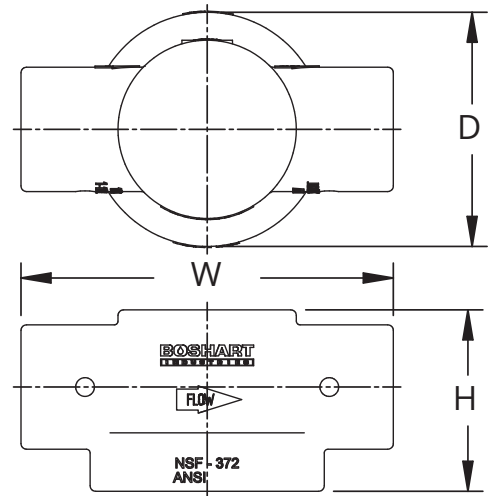

14SF-FH10-BII



14SF-FH10-BII
&
14SF-FH20-BII

Clamp Kit

Part No.	Description
14SF-MCK10	For 1" filter & separator - comes with 2 clamps and hardware

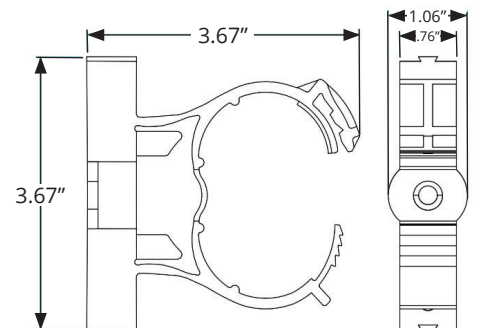
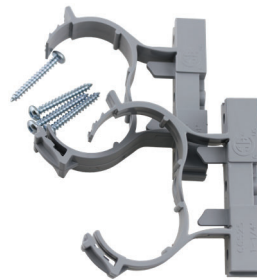

BOSHART
INDUSTRIES

25 Whaley Avenue, PO Box 310, Milverton, ON CANADA N0K 1M0
Tel: 800-561-3164

VISIT US ONLINE AT BOSHART.COM

For more information on installation, adjustment, repair & operation, visit Boshart Knowledge Base at SUPPORT.BOSHART.COM



Mounting Bracket

Part No.	Description
14SF-MBK	For 1-1/2" & 2" filter & separator - bracket with hardware

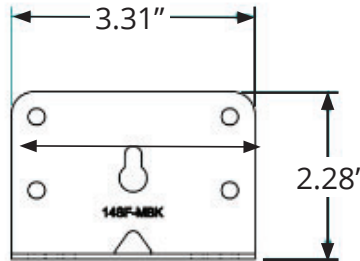
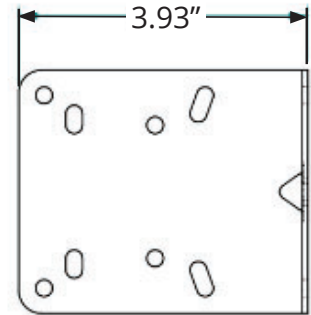
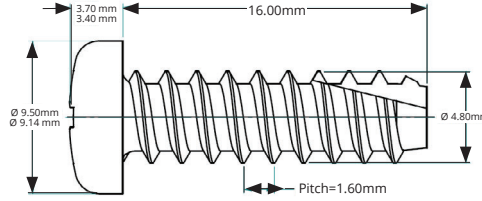
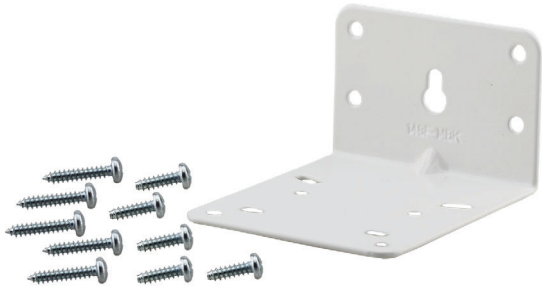

O-Ring Kit

Part No.	Description	Dimensions
14SF-ORK10	1" - includes AS568-120 & AS568-226	AS568-120 - 0.987" ID x 0.103" CS (25.07mm ID x 2.62mm CS) AS568-226 - 1.984" ID x 0.139" CS (50.39mm ID x 3.53mm CS)
14SF-ORK15	1-1/2" - includes AS568-216 & AS568-229	AS568-216 - 1.109" ID x 0.139" CS (28.17mm ID x 3.53mm CS) AS568-229 - 2.359" ID x 0.139" CS (59.92mm ID x 3.53mm CS)
14SF-ORK20	2" - includes AS568-220 & AS568-232	AS568-220 - 1.359" ID x 0.139" CS (34.52mm ID x 3.53mm CS) AS568-232 - 2.734" ID x 0.139" CS (69.44mm ID x 3.53mm CS)

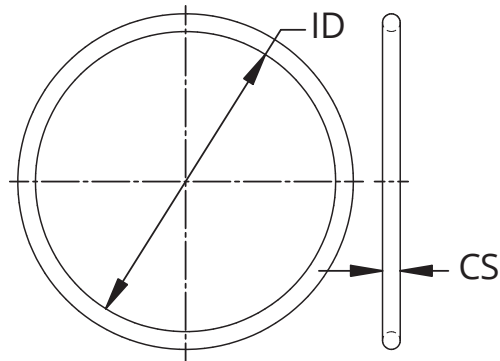

BOSHART
INDUSTRIES

25 Whaley Avenue, PO Box 310, Milverton, ON CANADA N0K 1M0
Tel: 800-561-3164

VISIT US ONLINE AT BOSHART.COM

For more information on installation, adjustment, repair & operation, visit Boshart Knowledge Base at SUPPORT.BOSHART.COM



Purve Valve

Part No.	Description
0929-05	1/2" PVC Ball Valve

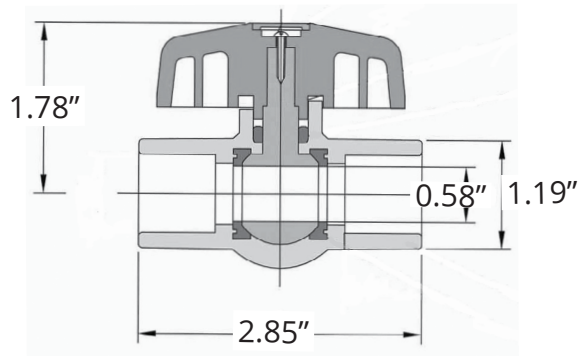

UV Cover

- Boshart UV Covers are commonly used in irrigation, well water, agricultural, and industrial filtration applications. They are designed to protect spin-out filters from UV exposure, weather, and physical damage while helping to inhibit algae growth caused by sunlight. Ideal for filters installed outdoors, in direct sunlight, or in algae-prone applications, these covers extend the lifespan of the filter body and help maintain water quality and system performance. Made from durable neoprene, they are installed by slipping over the clear filter bowl without the need for tools.

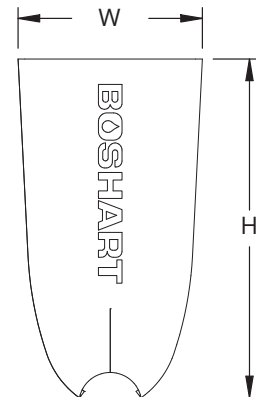

Part No.	Description	H		W	
		in	mm	in	mm
14SF-FB10-UVCG	1" Spin-Out Filter Neoprene UV Cover	6.28	159.51	3.42	86.87
	Fits 14SFHK-10, 14SFHK-10SMxxx, 14SFHK-M10, 14SFHK-M10SMxxx				
14SF-FB10XS-UVCG	1" Spin-Out Separator (Extended Bowl) Neoprene UV Cover	8.67	220.22	3.20	81.28
	Fits 14SFHK-S10, 14SFHK-S10SMxxx, 14SFHK-MS10, 14SFHK-MS10SMxxx				
14SF-FB15-UVCG	1-1/2" Spin-Out Filter/Separator Neoprene UV Cover	9.17	232.92	3.66	92.96
	Fits 14SFHK-15, 14SFHK-15SMxxx				
14SF-FB20-UVCG	2" Spin-Out Filter/Separator Neoprene UV Cover	10.20	259.08	4.65	118.11
	Fits 14SFHK-20, 14SFHK-20SMxxx				



25 Whaley Avenue, PO Box 310, Milverton, ON CANADA N0K 1M0
Tel: 800-561-3164

VISIT US ONLINE AT BOSHART.COM

For more information on installation, adjustment, repair & operation, visit Boshart Knowledge Base at SUPPORT.BOSHART.COM

