

# 08QTWH(P)NL SERIES NO LEAD NON-FREEZE WALL HYDRANT WITH SELF DRAINING VACUUM BREAKER

## 1/4 TURN HANDWHEEL

Non-Freeze Wall Hydrants can be installed through a wall and allow water to drain back out of the valve so freezing will not occur in the winter season. This prevents the need for winterizing and allows outdoor access to water year round.

**CAUTION:** Boshart will not be liable for any damage caused by failure to remove the hose or any attached device. Failure to do so may cause the hydrant to freeze. Freezing can lead to the tube bursting, resulting in property damage and may void the warranty. Boshart will not be liable for any damage caused by failure to remove the hose or attached device. Wall hydrants are not intended for potable water supply.

### FEATURES:

- Integral anti-siphon vacuum breaker to allow air to enter the valve, ensuring the valve drains completely
- Stem comes with a weep hole to allow back pressure relief when water is trying to siphon back into the homes water supply
- Chrome plated no lead brass body, tube and adapter
- Black cast 1/4 turn handwheel
- Inlet cartridge has built in spring loaded check valve for backflow prevention
- Sloped flange to support proper drainage, this is necessary for frost-proof performance
- NBR Packing
- Viton O-Ring seat
- POM (Acetal) Sealing discs are known for their outstanding toughness, they provide longevity (POM discs are not negatively affected by hard water and are not susceptible to cracking like ceramic discs)

### SPECIFICATION:

- Inlet Connection:
  - Threads conform to ANSI/ASME B1.20.1 Pipe Threads, General Purpose (Inch)
  - Sweat connections conform to ANSI B16.18 Cast Copper Alloy Solder Joint Pressure Fittings
  - Crimp PEX connections conform to ASTM F1807 Specification for Metal Insert Fittings Utilizing a Copper Crimp Ring for SDR9 Cross-linked Polyethylene (PEX) Tubing
- Outlet Connection:
  - ASME B1.20.7 Standard for Garden Hose Coupling Screw Threads (inch)

### RATINGS:

- Max Pressure Rating: 125 PSI
- Max Temperature Rating: 140°F (60°C)

### CERTIFICATION:

- NSF/ANSI Standard 372 Certified (Drinking Water System Components - Lead Content)
- CSA Standard B125.1 Plumbing Fittings Certified
- ASSE Standard 1019 Performance Requirements for Vacuum Breaker Wall Hydrants, Freeze Resistant, Automatic Draining Type Certified

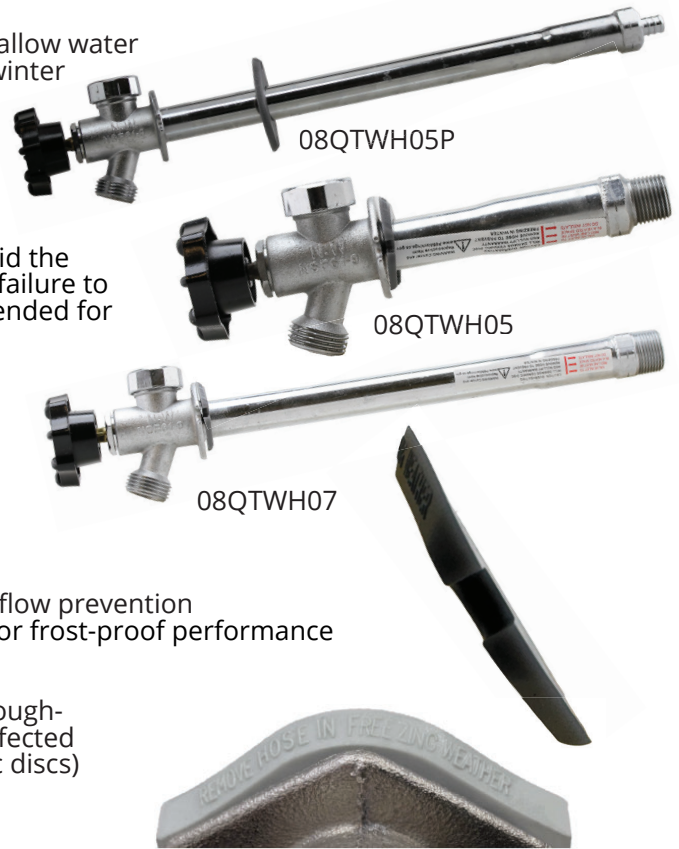

Grey flange wedge can be used to ensure upward tilt.  
"REMOVE HOSE IN FREEZING WEATHER"

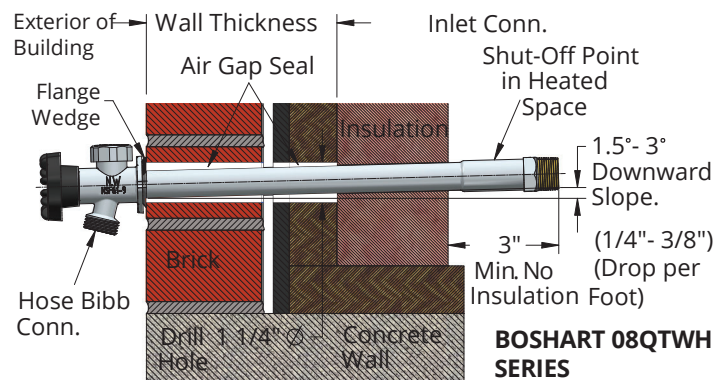

25 Whaley Avenue, PO Box 310, Milverton, ON CANADA N0K 1M0  
Tel: 800-561-3164  
VISIT US ONLINE AT BOSHART.COM



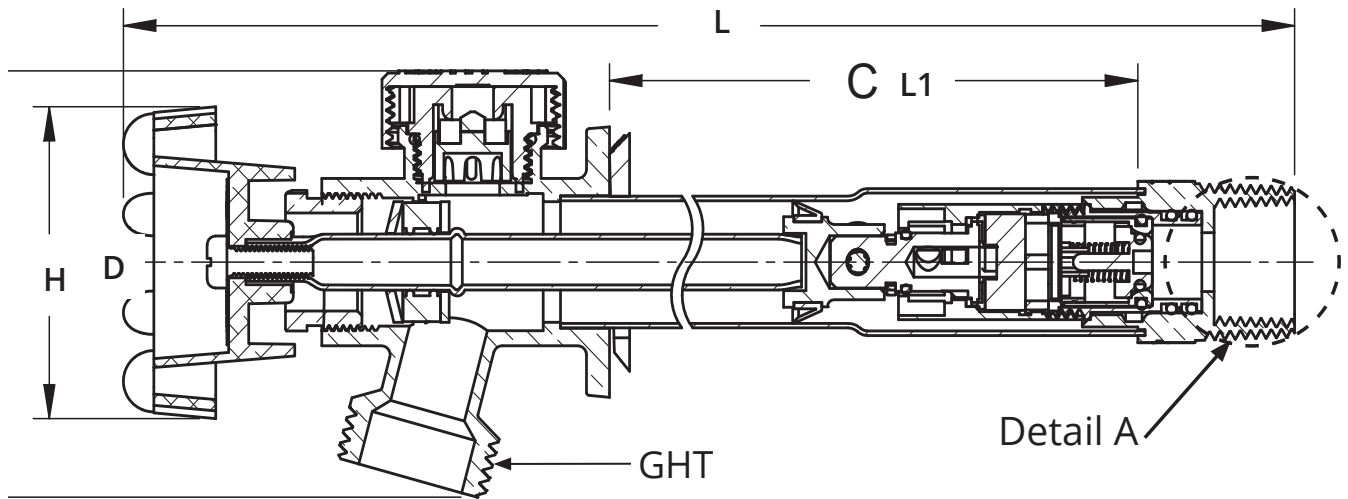

**\*\*Short burst of water can occur from vacuum breaker but will stop. If it continues to leak, vacuum breaker should be replaced\*\***

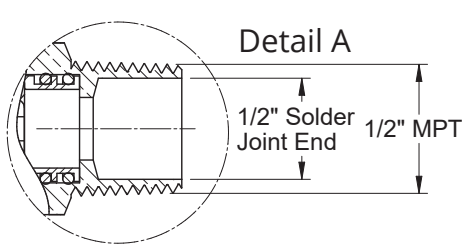

08QTWH05 Series End  
■ IC 1

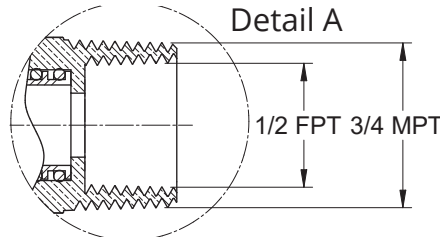

08QTWH07 Series End  
■ IC 2

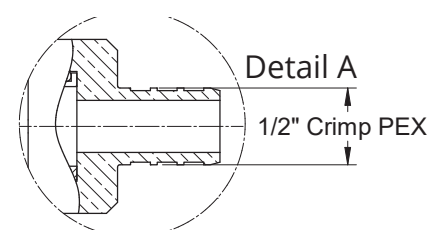

08QTWH05P Series End  
■ IC 3

DIMENSIONS												
Part No.	Inlet Connection	Size	D		L		L1		H		Weight	
			in	mm	in	mm	in	mm	in	mm	lbs	grams
08QTWH05-040NL	1/2" MPT x C (Solder/Sweat)	4"	2.20	56.00	8.78	222.80	4.00	101.60	3.20	81.30	1.15	520
08QTWH05-060NL		6"			10.78	273.60	6.00	152.40			1.23	560
08QTWH05-080NL		8"			12.78	324.40	8.00	203.20			1.29	585
08QTWH05-100NL		10"			14.78	375.20	10.00	254.00			1.36	615
08QTWH05-120NL		12"			16.78	426.00	12.00	304.80			1.43	650
08QTWH05-140NL		14"			18.79	476.80	14.00	355.60			1.50	680
08QTWH07-100NL	3/4" MPT x 1/2" FPT	10"	2.20	56.00	14.78	375.20	10.00	254.00	3.20	81.30	1.40	635
08QTWH07-120NL		12"			16.78	426.00	12.00	304.80			1.48	670
08QTWH07-140NL		14"			18.79	476.80	14.00	355.60			1.54	700
08QTWH05P-080NL	1/2" PEX	8"	2.20	56.00	12.78	324.40	8.00	203.20	3.20	81.30	1.29	585
08QTWH05P-100NL		10"			14.78	375.20	10.00	254.00			1.36	615
08QTWH05P-120NL		12"			16.78	426.00	12.00	304.80			1.43	650
08QTWH05P-140NL		14"			18.79	476.80	14.00	355.60			1.50	680



25 Whaley Avenue, PO Box 310, Milverton, ON CANADA N0K 1M0  
Tel: 800-561-3164  
VISIT US ONLINE AT BOSHART.COM



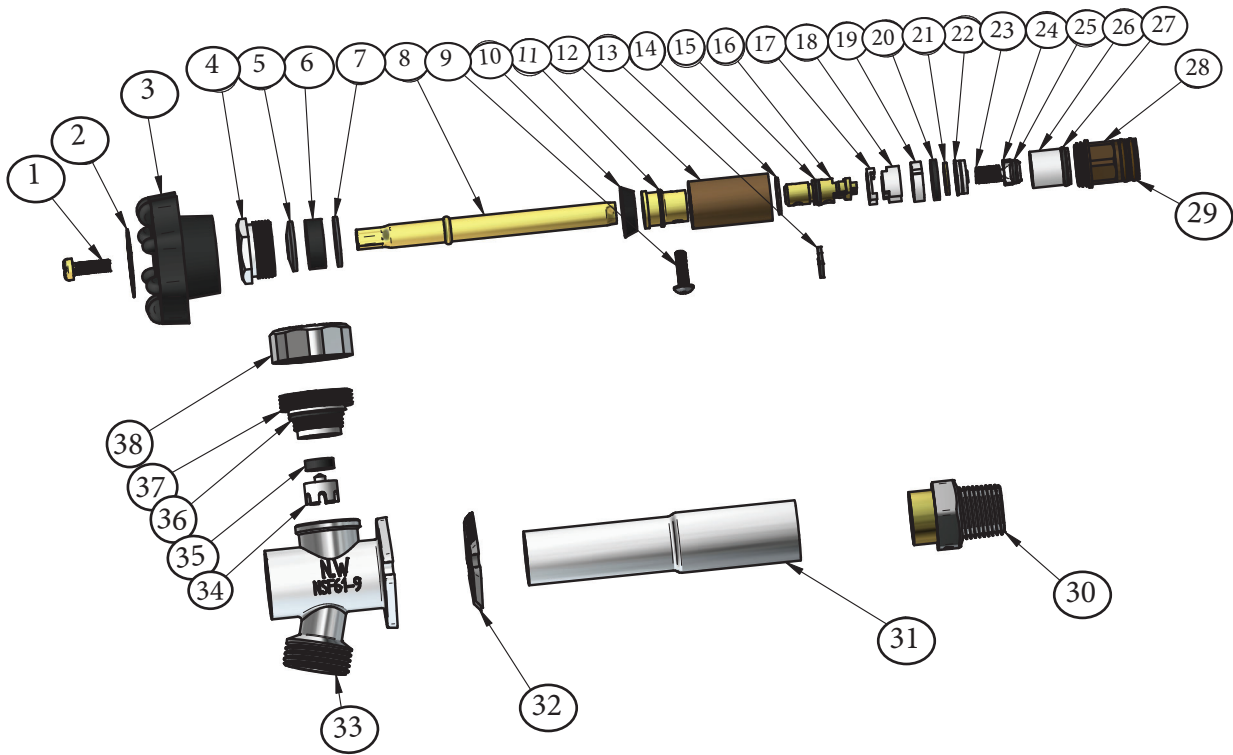

Material List		
Part No.	Part Name	Material
1	Handle Screw	C26000 NL Brass
2	Name Plate	Aluminum
3	Handwheel	Aluminum
4	Stem Packing Nut	C3604 Brass
5	Stem Packing Washer	SS304 Stainless Steel
6	Stem Packing	NBR (Nitrile Butadiene Rubber)
7	Stem Packing Flat Washer	SS304 Stainless Steel
8	Stem Pipe	C27000 NL Brass
9	Set Screw	SS304 Stainless Steel
10	Cup Washer	NBR (Nitrile Butadiene Rubber)
11	Stem Connector	C46400 NL Brass
12	Cartridge Body	C46400 NL Brass
13	C Clip	SS304 Stainless Steel
14	Plastic Square Ring	PTFE (Polytetrafluoroethylene)
15	Cartridge Stem O-Ring	NBR (Nitrile Butadiene Rubber)
16	Cartridge Stem	C46400 NL Brass
17	Ceramic Fixer	POM (Polyoxymethylene)
18	Ceramic Disc	Ceramic
19	Ceramic Disc	Ceramic

20	Cartridge Square Ring	EPDM (Ethylene Propylene Diene Monomer)
21	Brass Square Ring	C46400 NL Brass
22	Check Valve Seat	POM (Polyoxymethylene)
23	Check Valve Spring	SS304 Stainless Steel
24	Check Valve Piston	POM (Polyoxymethylene)
25	Check Valve Piston O-Ring	NBR (Nitrile Butadiene Rubber)
26	Check Valve Retainer	POM (Polyoxymethylene)
27	Check Valve O-Ring	NBR (Nitrile Butadiene Rubber)
28	Cartridge End	C46400 NL Brass
29	Cartridge End O-Ring	Viton
30	Adapter	C46400 NL Brass
31	Tube	C27000 NL brass
32	Flange Wedge/Insert Spacer	POM (Polyoxymethylene)
33	Valve Body	C6802 NL Bronze
34	Vaccum Breaker Disk	POM (Polyoxymethylene)
35	Vaccum Breaker Seat	NBR (Nitrile Butadiene Rubber)
36	Vaccum Breaker Body O-Ring	NBR-RUBBER
37	Vacuum Breaker Body	POM
38	Vaccum Breaker Cap	ABS Plastic



25 Whaley Avenue, PO Box 310, Milverton, ON CANADA N0K 1M0  
 Tel: 800-561-3164  
 VISIT US ONLINE AT BOSHART.COM

For more information on installation, adjustment, repair & operation, visit Boshart Knowledge Base at SUPPORT.BOSHART.COM



# REPLACEMENT PARTS

REPLACEMENT PARTS		
Part No.	Description	Components
08QTDHPT-HDK	Replacement Handle Kit	1, 2, 3
08QTDHPT-SPK	Replacement Stem Packing Kit	4, 5, 6, 7
08QTDHPT-SA04	4" Replacement Stem Assembly	8 to 29
08QTDHPT-SA06	6" Replacement Stem Assembly	
08QTDHPT-SA08	8" Replacement Stem Assembly	
08QTDHPT-SA10	10" Replacement Stem Assembly	
08QTDHPT-SA12	12" Replacement Stem Assembly	
08QTDHPT-SA14	14" Replacement Stem Assembly	
08QTDHPT-ORK	Replacement O-Ring Kit	29 (Qty. 2)
08QTDHPT-INS	Replacement Insert Spacer	32
08QTDHPT-VBK	Replacement Vacuum Breaker Kit	34, 35, 36, 37
08QTDHPT-VBC	Replacement Vacuum Breaker Cap	38

## 08QTDHPT-HDK - Replacement Handle

- Kit includes handwheel, nameplate and screw

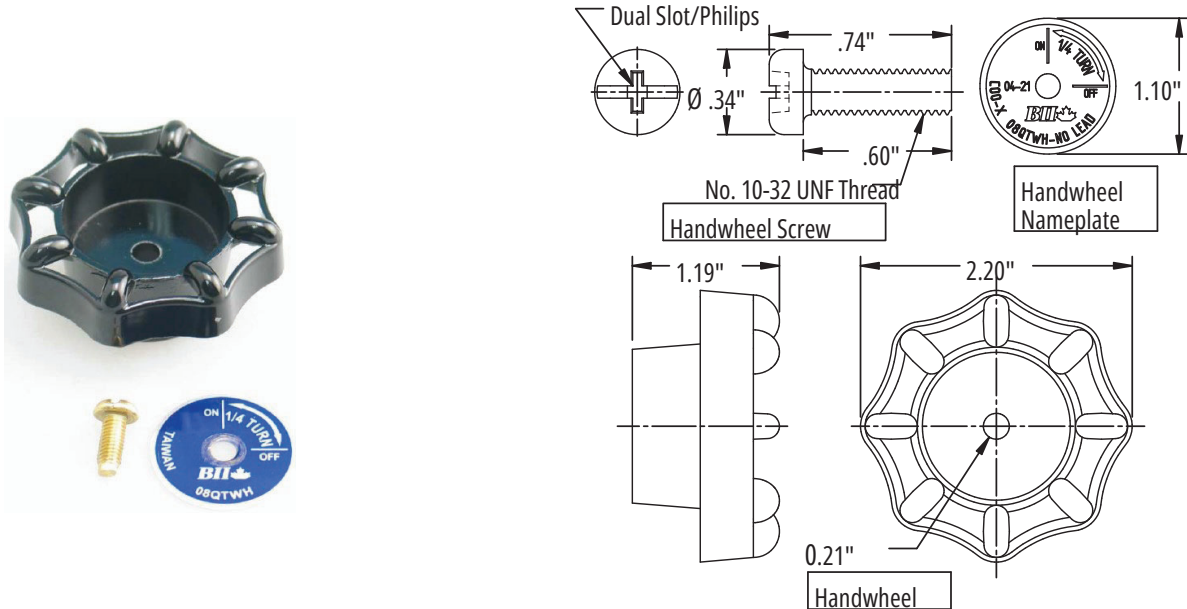

25 Whaley Avenue, PO Box 310, Milverton, ON CANADA N0K 1M0  
 Tel: 800-561-3164  
 VISIT US ONLINE AT BOSHART.COM



## 08QTHWPT-SPK - Stem Packing Kit

- Includes bonnet, washer, stem packing and stop washer

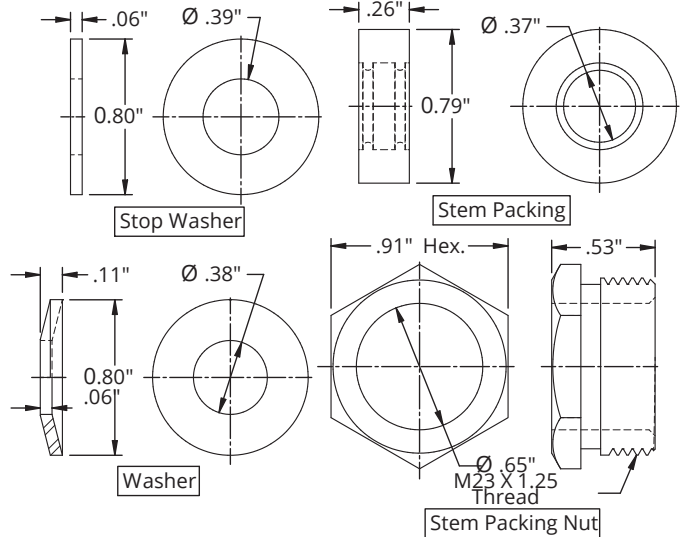

### Determining Stem Length

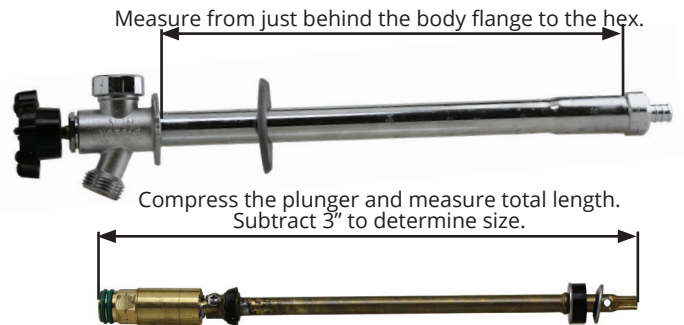

## 08QTHWPT-SA(xx) - Stem Assembly

- Available in 4", 6", 8", 10", 12" and 14" lengths

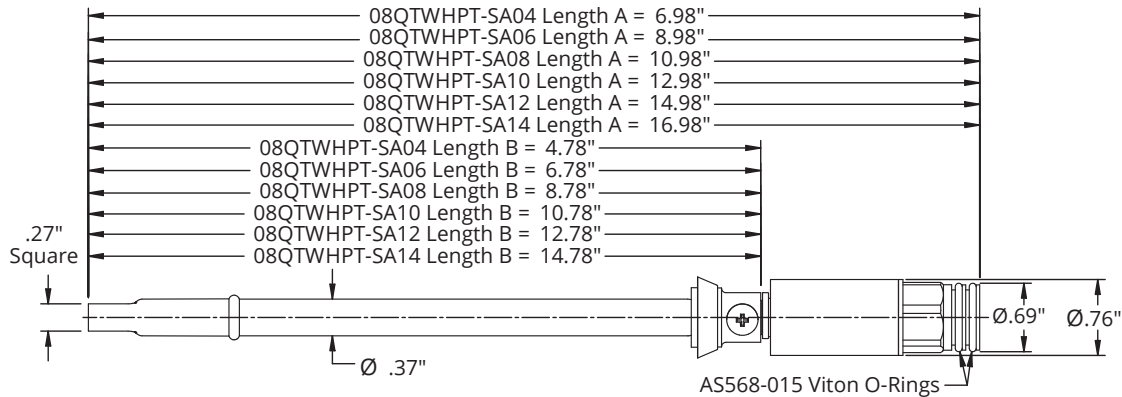

## 08QTHWPT-ORK - O-Ring Kit

- Kit includes 2 O-rings
- AS568-113 Standard O-Ring Size

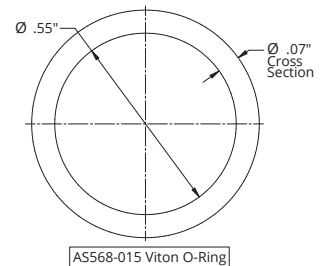

**BOSHART**  
INDUSTRIES

25 Whaley Avenue, PO Box 310, Milverton, ON CANADA N0K 1M0  
Tel: 800-561-3164  
VISIT US ONLINE AT [BOSHART.COM](http://BOSHART.COM)

For more information on installation, adjustment, repair & operation, visit Boshart Knowledge Base at [SUPPORT.BOSHART.COM](http://SUPPORT.BOSHART.COM)



## 08QTHWPT-INS - Insert Spacer

- Ensures downward tilt

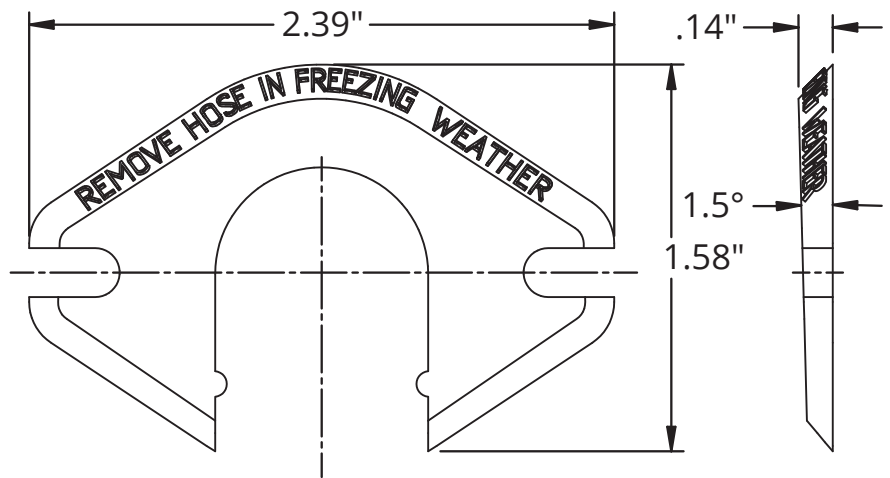

## 08QTHWPT-VBK - Vacuum Breaker Kit

- Gaskets included

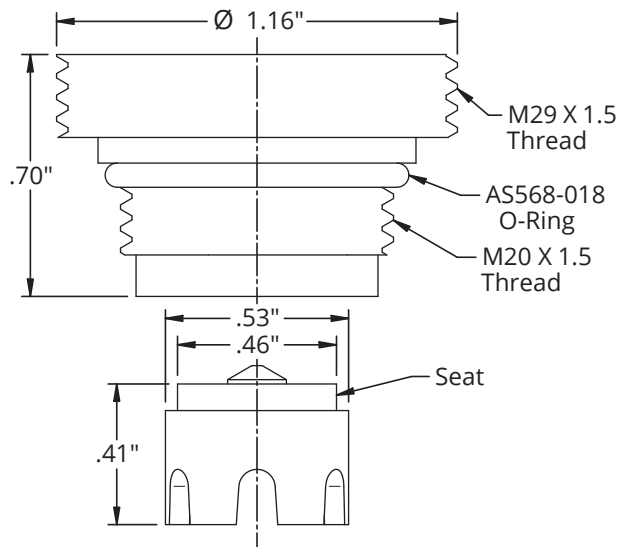
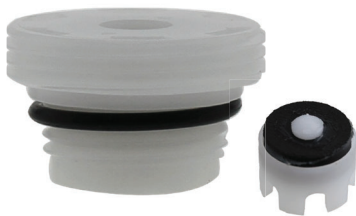

## 08QTHWPT-VBC - Vacuum Breaker Cap

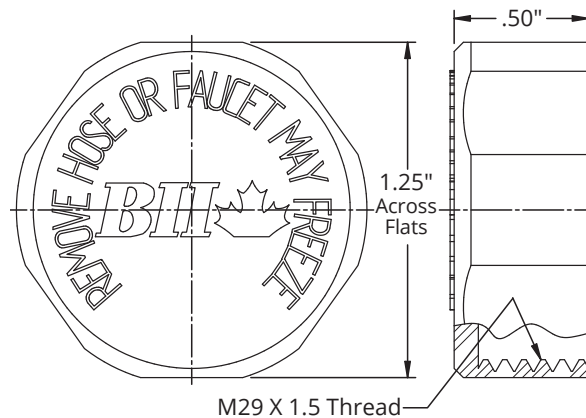

**BOSHART**  
INDUSTRIES

25 Whaley Avenue, PO Box 310, Milverton, ON CANADA N0K 1M0  
Tel: 800-561-3164  
VISIT US ONLINE AT [BOSHART.COM](http://BOSHART.COM)

For more information on installation, adjustment, repair & operation, visit Boshart Knowledge Base at [SUPPORT.BOSHART.COM](http://SUPPORT.BOSHART.COM)



# How do you install a 08QTWH quarter turn frost-free wall hydrant?

Before getting started, it is extremely important to make sure you have an appropriate length of wall hydrant for your wall thickness. The inlet connection MUST extend through the wall and any insulation so that the connection is inside the warm space at a position that is easily accessible to make the water line connection.

**Step #1** - Drill a 1-1/4" diameter hole on a 5° upward angle from the outside to ensure you have sufficient downward slope to the outlet for drainage. Drill through the foundation wall or the floor joist band. Then insert the faucet tube from the outside. **WARNING:** Do not drill the hole horizontally. A 1-1/4" diameter hole will only allow the tube to be installed at approximately up to 1.5°. It does not have enough play to properly slope the wall hydrant.

**Step #2** - Position the faucet so that the faucet's spout is pointing directly downward. To check the spout's position from the inside of the building, place the "TOP" marking on the hex by the inlet connection pointing up.

**Step #3** - Place the angled, wedge-shaped, plastic flange with the thick side upwards to ensure the hydrant tube has a minimum of a 5° angle downwards to the spout to insure proper drainage. Then, secure the wall faucet flange on to the wall with two #8 or #10 wood or masonry screws depending on your construction. Failure to ensure the 5° angle will result in trapped water which will cause the wall faucet to freeze and fail, damaging internal components or in the worst-case scenario, burst the tube and potentially cause water damage.

**Step #4** - If you are using the internal solder (sweat) connection, the stem assembly MUST be removed to prevent damage to the rubber seals due to excessive heat. To remove the stem assembly, unscrew the hexagon nut behind the hand wheel and then pull the valve stem straight out of the tube by pulling on the handwheel.

**Step #5** - Fill the free space (air gap) around the tube with caulking to seal the air gap.

**Step #6** - When insulating DO NOT insulate beyond 3" from the inlet connection. The 3" section of the tube from the inlet end must not be insulated from the warmth of the building to ensure it does not freeze. Insulating too close to or over the inlet connection may cause the wall faucet to freeze and fail, damaging internal components, or in worst-case scenario, burst the tube and potentially cause water damage.

## IMPORTANT WARNINGS:

**#1 - Winterization:** When the cold weather arrives, it is crucial to remove the hose to ensure proper drainage. Failure to remove the hose WILL cause the wall faucet to freeze and fail, damaging internal components. It is not a product defect! Turn the handle to the closed position (clockwise) and always detach the hose from the spout if there is any chance of frost.

**#2 - Keep Inside Heated:** Wall hydrants are frost-proof because the water is shut off inside the heated portion of the building. If the building is left unheated for an extended period, the water supply lines must be drained and all plumbing fixtures and components properly winterized to prevent freezing.

For troubleshooting and selection guide, visit our Knowledge Base.

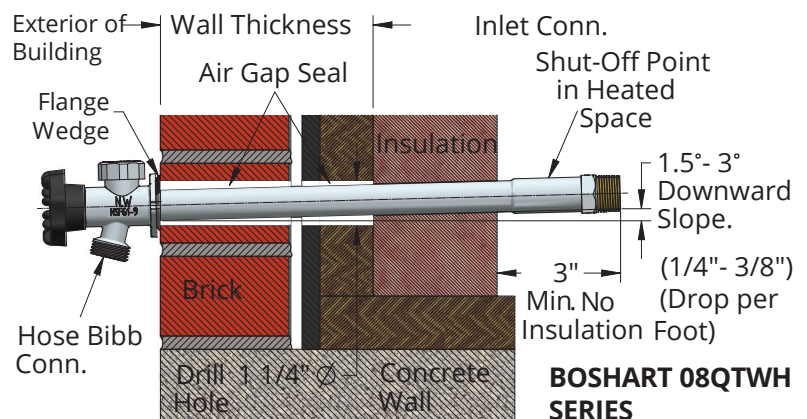

**BOSHART**  
INDUSTRIES

25 Whaley Avenue, PO Box 310, Milverton, ON CANADA N0K 1M0  
Tel: 800-561-3164  
VISIT US ONLINE AT [BOSHART.COM](http://BOSHART.COM)

For more information on installation, adjustment, repair & operation, visit Boshart Knowledge Base at [SUPPORT.BOSHART.COM](http://SUPPORT.BOSHART.COM)

