

# 28-SSDPC SERIES - 304 STAINLESS STEEL DROP PIPE COUPLING

## APPLICATIONS:

- Designed for submersible pump applications.
- When installing, use both PTFE (Polytetrafluoroethylene) tape and thread seal compound that is specifically designed for stainless steel connections to prevent galling.

## SPECIFICATION:

- Materials conform to ASTM A351.
- Extra deep NPT threading for increased thread engagement / load bearing capacity (Based on ANSI/ ASME B1.20.1).
- 45° inside chamfer at both ends for trouble-free starting of threads.
- Wrench flats on each side for easier installation.

## CERTIFICATION:

- NSF/ANSI Standard 372 Certified (Drinking Water System Components - Lead Content)  
(Stainless Steel alloys do not contain any lead 0.00% Pb)



PRESSURE & TEMPERATURE RATING	
Temperature °F (°C)	Class 150, PSIG
-20 to 150 (-29 to 66)	300
200 (93)	265
250 (121)	225
300 (149)	185
350 (177)	150

MATERIAL LIST - 304 Stainless Steel	
Name	Percent of Composition
Iron (FE)	64.0 - 72.0
Carbon (C)	0.08 max
Silicon (Si)	2.00 max
Manganese (Mn)	1.50 max
Phosphorus (P)	0.04 max
Sulfur (S)	0.04 max
Chromium (Cr)	18.0 - 21.0
Nickel (Ni)	8.0 - 11.0
Molybdenum (Mo)	0.05 max

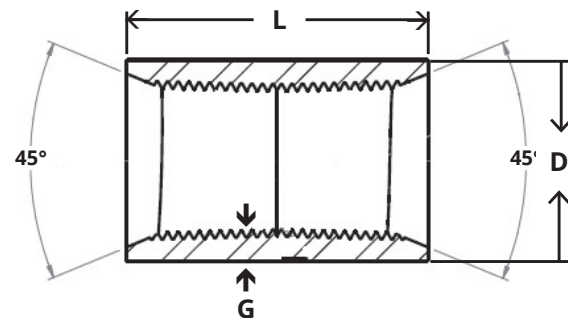
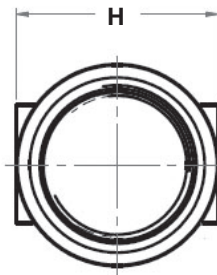

Max Weight Holding Capacity:

\*Based on submersible pump & pump cable not exceeding 400lbs.

DIMENSIONS													
Part No.	Size	Max Weight Holding Capacity*	Max Pump Set Depth	H		D		L		G		Weight	
	FPT			Lbs	Feet	in	mm	in	mm	in	mm	in	mm
28-SSDPC-10	1"	3130	1300	1.66	42.16	1.66	42.16	2.50	63.50	0.19	4.98	0.705	320
28-SSDPC-12	1-1/4"	4187	1306	2.00	50.80	2.00	50.80	2.50	63.50	0.20	5.08	0.816	370
28-SSDPC-15	1-1/2"	4929	1258	2.29	58.04	2.29	58.04	2.50	63.50	0.22	5.59	1.036	470
28-SSDPC-20	2"	5400	1000	2.75	69.85	2.75	69.85	2.50	63.50	0.21	5.41	1.213	550

**Disclaimer:** The weight rating only applies to the 28-SSDPC-xx. All tensile testing results consistently conclude in joint failure due to the elongation of the male threads on the drop/riser pipe. It is therefore recommended that the installer acquire the male pipe thread load capacity data of the drop/riser pipe from the pipe manufacturer. The loads must not exceed either the coupling or drop/riser pipe load capacity. The maximum load bearing weight of the pipe will vary significantly depending on the pipe material. This data is only a guide. The final responsibility for the design of the well lies with the well designer/installer.

**BOSHART**  
**INDUSTRIES**

25 Whaley Avenue, PO Box 310, Milverton, ON CANADA N0K 1M0  
Tel: 800-561-3164

VISIT US ONLINE AT [BOSHART.COM](http://BOSHART.COM)



## INSTALLATION INSTRUCTIONS:

When installing Boshart 304 Stainless Steel Drop Pipe Couplings, the use of PTFE (Polytetrafluoroethylene) tape and a thread sealant compound specifically designed for stainless steel connections is recommended to prevent galling of threads. (Do not use petroleum based pipe thread sealants.) Care must be taken not to overtighten the joint.

### Installation Steps:

- Check the threads to ensure they are clean and free of foreign debris.
- Apply thread sealant compound and PTFE tape.
- Hand tighten.
- Wrench tighten an additional 1 to 2-1/2 turns.

Extra Deep FPT Thread  
to Provide More  
Thread Engagement  
Which Increases Joint  
Strength

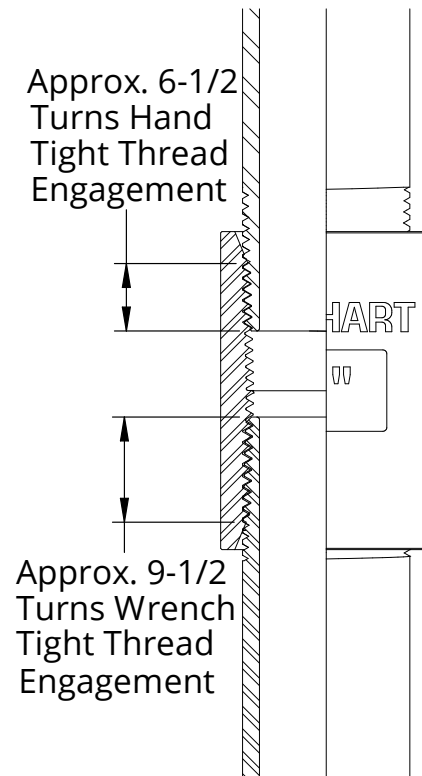

**BOSHART**  
**INDUSTRIES**

25 Whaley Avenue, PO Box 310, Milverton, ON CANADA N0K 1M0  
Tel: 800-561-3164

VISIT US ONLINE AT [BOSHART.COM](http://BOSHART.COM)

For more information on installation,  
adjustment, repair & operation, visit  
Boshart Knowledge Base at  
[SUPPORT.BOSHART.COM](http://SUPPORT.BOSHART.COM)

