

17FVSS - 304SS THREADED FOOT VALVES

Foot valves are also referred to as one-way or non-return valves. Foot valves are commonly used with well pumps, in storage tanks, irrigation systems, pools, ponds, reservoirs, or anywhere a suction pump is used. Their purpose is to prevent reverse flow and maintain system pressure in pressurized pumping systems, they are installed on the end of the suction line of any suction pump. The foot valve not only prevents fluid / water from flowing backward when the pump is off, the valve also keeps the fluid trapped in the suction pipe when the pump stops, sustaining the prime for the pump, and preventing pump burnout. Foot valves work automatically, opened by the pump's suction pulling the valve poppet open against a low tension spring, normally ½ PSI or less cracking pressure (cracking pressure is the pressure it takes to open the valve). When the pump stops the valve starts closing automatically with assistance of the spring as the flow slows, and is completely sealed before it comes to a full stop. This eliminates flow reversal which would cause the poppet to slam against the seat causing hydraulic shock or water hammer. Without a foot valve gravity would cause the water or fluid to flow in the reverse direction resulting in the loss of prime and system pressure.

APPLICATIONS:

- Foot valves are mainly used in potable water and irrigation applications

SPECIFICATIONS:

- Threads conform to ANSI/ASME B1.20.1
- Cast 304SS body and poppet
- FPM (Viton®) rubber O-ring seal
- Cracking pressure equal to or less than 0.5 PSI for 1/2" through 4" valves
- Best practice is to install foot valves vertically with the arrow pointed up in the direction of liquid flow. (1/2" through 1-1/4" sizes can be installed horizontally)

CERTIFICATION:

- NSF/ANSI/CAN Standard 372 Certified (Drinking Water System Components - Lead Content - Stainless Steel alloys do not contain any lead, 0.00% Pb)

RATINGS:

- Maximum pressure rating: 200 PSI WOG Non-Shock
- Maximum temperature rating: 180 °F (82 °C)
- Headloss - see page 3 for detailed information
- Velocity - see page 3 for detailed information
- CV Rating - see page 3 for detailed information



BOSHART
INDUSTRIES

25 Whaley Avenue, PO Box 310, Milverton, ON CANADA N0K 1M0
Tel: 800-561-3164

boshart.com ♦ blog.boshart.com

MATERIAL LIST	
Part Name	Material
Hex Nut	304SS
Cup Washer	304SS
Spring	304SS
Body	304SS
O-ring	FPM (Viton®) (Fluoro Rubber)
Poppet	304SS
Screw	304SS
Screen Cap	304SS
Screen	304SS

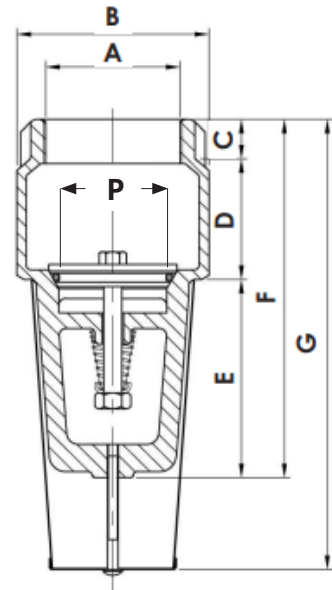

DIMENSIONS													
Part No.	A	B		C		D		P		F		G	
		in	mm	in	mm	in	mm	in	mm	in	mm	in	mm
17FVSS-050	1/2" FPT	1.26	32.00	0.39	10.01	0.96	24.51	0.515	13.08	2.93	74.49	3.37	85.59
17FVSS-075	3/4" FPT	1.49	38.00	0.40	10.21	0.93	23.80	0.694	17.63	3.20	81.50	3.35	85.19
17FVSS-100	1" FPT	1.77	45.01	0.47	11.99	1.08	27.51	0.852	21.64	3.70	94.00	4.57	116.10
17FVSS-125	1-1/4" FPT	2.12	54.00	0.53	13.49	1.20	30.51	1.181	29.10	4.12	104.70	5.00	127.00
17FVSS-150	1-1/2" FPT	2.36	59.99	0.61	15.49	1.43	36.50	1.234	31.34	5.13	130.51	5.94	150.90
17FVSS-200	2" FPT	3.03	76.99	0.65	16.51	1.90	48.31	1.771	44.98	5.81	147.80	7.33	186.21
17FVSS-300	3" FPT	4.68	119.00	1.18	30.00	2.52	64.01	2.950	74.93	7.87	200.00	9.31	236.60
17FVSS-400	4" FPT	5.90	150.00	1.37	35.00	3.38	86.00	3.929	99.80	9.74	247.50	13.67	347.40

SCREEN INFORMATION*														
Part No.	Size	Screen Length (E)		Screen Open Area		Hole Diameter		Distance (Metal) Between Holes		Hole Spacing Center to Center		Weight		
		in	mm	in ²	cm ²	in	mm	in	mm	in	mm	lbs	grams	
17FVSS-050	1/2" FPT	2.0	50.8	1.24	8.00	0.11	2.8	0.08	2.0	0.19	4.8	0.31	140	
17FVSS-075	3/4" FPT	2.0	50.8	1.52	9.80	0.11	2.8	0.08	2.0	0.19	4.8	0.40	180	
17FVSS-100	1" FPT	3.0	76.2	2.57	16.6	0.11	2.8	0.08	2.0	0.19	4.8	0.62	280	
17FVSS-125	1-1/4" FPT	3.25	82.6	3.76	24.2	0.11	2.8	0.08	2.0	0.19	4.8	0.86	390	
17FVSS-150	1-1/2" FPT	3.88	98.5	5.56	35.9	0.11	2.8	0.08	2.0	0.19	4.8	1.17	530	
17FVSS-200	2" FPT	4.76	121.0	7.66	49.4	0.11	2.8	0.08	2.0	0.19	4.8	2.16	980	
17FVSS-300	3" FPT	5.51	140.0	15.36	99.1	0.11	2.8	0.12	3.0	0.23	5.8	6.61	3000	
17FVSS-400	4" FPT	8.78	223.0	23.79	153.5	0.11	2.8	0.12	3.0	0.23	5.8	11.90	5400	

*All dimensions subject to minor variations.



25 Whaley Avenue, PO Box 310, Milverton, ON CANADA N0K 1M0
Tel: 800-561-3164

boshart.com ♦ blog.boshart.com

FLOW COEFFICIENT: Flow Coefficient (Cv) is the number of U.S. gallons that can pass through a valve when it is in the fully opened position at a pressure drop of 1 PSI. Testing is typically done by running water (specific gravity of 1.0 centistoke viscosity) at 60°F (°C) unless stated otherwise.

Valve Size	1/2"	3/4"	1"	1-1/4"	1-1/2"	2"	3"	4"
Flow Coefficient (CV)	5.0	6.2	9.6	20.1	30.1	41.2	65.0	95.0

The Cv is used to properly size valves, so they have minimal effect on the hydraulic efficiency of your system. Flow Coefficient or Cv is one of the most important things to know for selecting the right size of valve. For example, a 1-1/4" valve with a Cv of 20.1 has an effective port area in the fully open position such that it is capable of passing 20.1 GPM of water with a pressure drop of 1 PSI.

VELOCITY: It is also important to take Flow Velocity into consideration when selecting a valve, larger pipe is more expensive, however keeping the water velocity low is important to limit pressure losses due to friction, water hammer, and pipe movement due to water momentum changes inside the pipe. It is recommended to size piping to maintain a water velocity of 5 ft/second (1.524 LPM). Five feet per second is a threshold that is widely accepted by engineers and designers because beyond this velocity, the friction losses, danger of water hammer, and pipe movement due to water momentum changes are deemed to be too high.

Maximum Flow Rates to Maintain Fluid Velocity of 5 fps (1.523m/s)								
Nominal Valve / Pipe Size	1/2"	3/4"	1"	1-1/4"	1-1/2"	2"	3"	4"
GPM at 5 fps (feet / second)	3.06	6.89	12.25	19.15	27.57	49.02	110.29	196.08
LPM at 1.524 m/s (meters / second)	11.57	26.04	46.30	72.34	104.17	185.19	416.67	704.75

HEAD LOSS: Head loss is a measure of the reduction in the total head (sum of elevation head, velocity head and pressure head) of the fluid as it moves through a fluid system. The chart below provides the head loss data for these series of valves. You will notice that when the flow velocity is maintained the head loss across the valves is typically 1.5 PSI or less (except for the 4" valves at approx. 2.3 PSI)

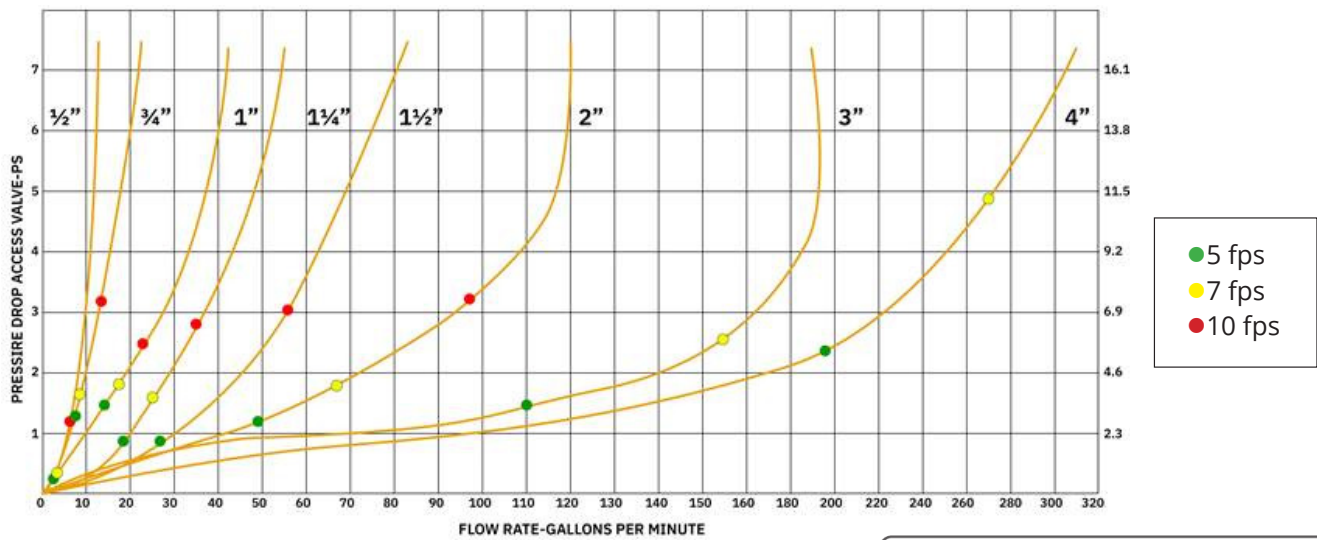

For more information on installation, adjustment, repair & operation, visit Boshart Knowledge Base at SUPPORT.BOSHART.COM



25 Whaley Avenue, PO Box 310, Milverton, ON CANADA N0K 1M0
Tel: 800-561-3164

boshart.com ♦ blog.boshart.com