

BSC SERIES- ABS SUMP PUMP CHECK VALVES

SPECIFICATIONS:

- Full port valve design
- Flapper opens 100%
- Maximum temperature rating: 140 °F (60 °C)
- Made from durable Acrylonitrile Butadiene Styrene (ABS)
- Rubber boot installation: 10 feet of head / 4.3 PSI
- Solvent weld installation: 58 feet of head / 25 PSI
- Flapper seat design reduces water hammer and prevents debris buildup, ensuring proper seating.
- Standard part numbers have a drill indicator. -AR part numbers have an air release hole drilled.

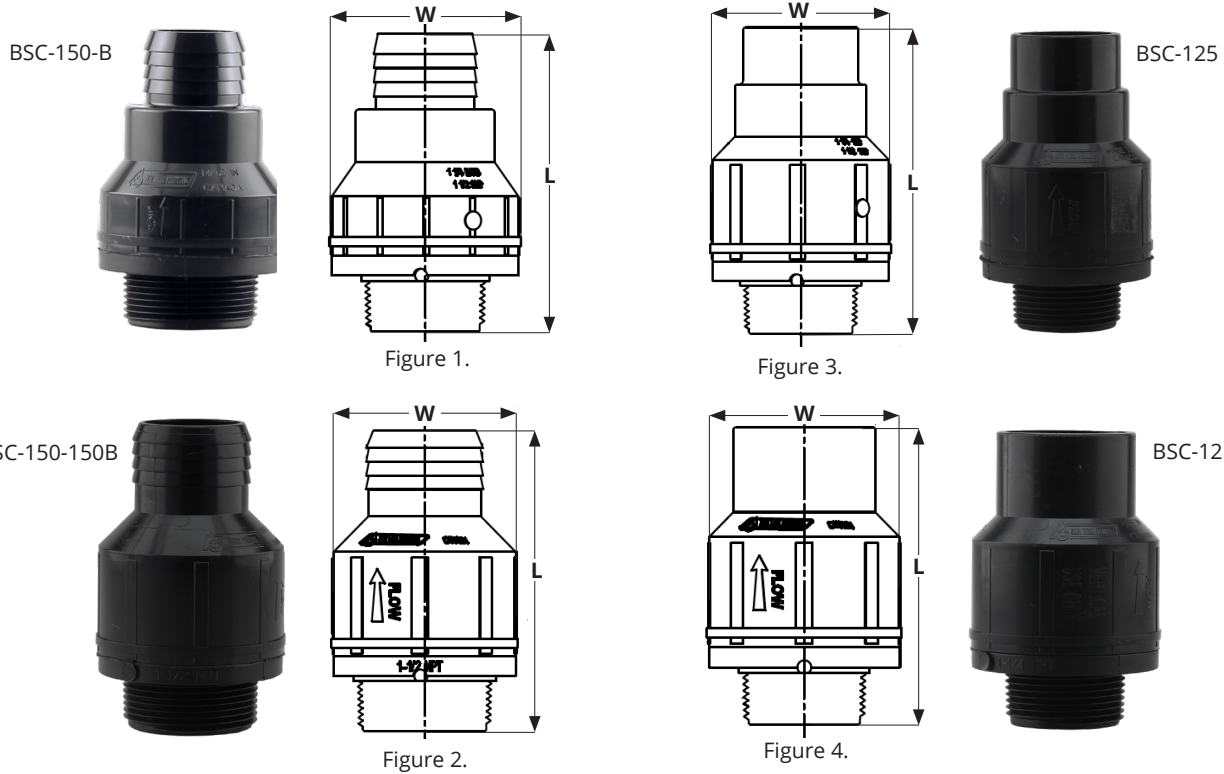

DIMENSIONS

Fig. No.	Part No.		Inlet Connection	Outlet Connection	L		W		Weight grams
	Standard	Air Release			in	mm	in	mm	
1	BSC-125-B	BSC-125-B-AR	1-1/4" MPT	1-1/4" Barb or 1-1/2" Spigot	4.06	103.1	2.61	66.3	69
	BSC-150-B	BSC-150-B-AR	1-1/2" MPT	1-1/4" Barb or 1-1/2" Spigot	4.07	103.4	2.61	66.3	73
2	BSC-150-150B	BSC-150-150B-AR	1-1/2" MPT	1-1/2" Barb	4.23	107.4	2.61	66.3	83
3	BSC-125	BSC-125-AR	1-1/4" MPT	1-1/4" or 1-1/2" Spigot	4.06	103.1	2.61	66.3	83
	BSC-150	BSC-150-AR	1-1/2" MPT	1-1/4" or 1-1/2" Spigot	4.44	112.8	2.61	66.3	87
4	BSC-125-150S	BSC-125-150S-AR	1-1/4" MPT	1-1/2" Spigot	4.06	103.1	2.61	66.3	83
	BSC-150-150S	BSC-150-150S-AR	1-1/2" MPT	1-1/2" Spigot	4.00	101.6	2.61	66.3	82

For more information on installation, adjustment, repair & operation, visit Boshart Knowledge Base at

SUPPORT.BOSHART.COM



BOSHART INDUSTRIES

25 Whaley Avenue, PO Box 310, Milverton, ON CANADA N0K 1M0
Tel: 800-561-3164

boshart.com ♦ blog.boshart.com