

# 0925-NL SERIES PVC BLOCKED TRUE UNION BALL VALVE

## SPECIFICATION:

- Threads conform to ANSI/ASME B1.20.1
- Slip connections conform to ASTM D2466
- Working Temperature Range: 41°F to 122°F (5°C to 55°C)
- Max Pressure Rating: 150 PSI @ 73°F(22°C)
- Grey PVC body, suitable for both schedule 40 & 80 pipe
- Double union / double block design permits in-line maintenance without disconnecting pipe
- Ends are blocked with bayonet style lock to prevent ball from being blown out
- Comes complete with both threaded and slip end connections
- Blue ABS handle is equipped with removable spanner device

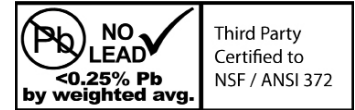

## CERTIFICATION:

- NSF/ANSI Standard 61 & 372 Certified

MATERIAL LIST	
Name	Material
Body	UPVC
Stem O-ring	EPDM
Stem	UPVC
Ball	UPVC
Ball Seat	PTFE
End Block O-ring	EPDM
End Block	UPVC
Union O-ring	EPDM
End Connector	UPVC
Union Nut	UPVC
Handle	ABS

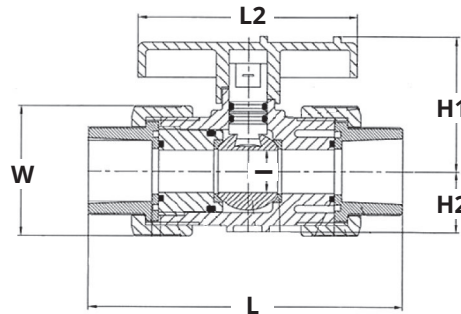

DIMENSIONS														
Part No.	Nominal Size	I		W		H1		H2		L		L2		Weight grams
		inches	mm	inches	mm	inches	mm	inches	mm	inches	mm	inches	mm	
0925-05NL	1/2"	0.51	13.00	1.83	46.50	1.89	48.00	0.81	20.50	4.49	114.00	3.07	78.00	190
0925-07NL	3/4"	0.71	18.00	2.17	55.00	2.24	57.00	1.02	26.00	5.31	135.00	3.62	92.00	308
0925-10NL	1"	0.91	23.00	2.60	66.00	2.60	66.00	1.30	33.00	5.83	148.00	3.94	100.00	467
0925-12NL	1-1/4"	1.18	30.00	3.23	82.00	2.91	74.00	1.50	38.00	6.61	168.00	4.33	110.00	754
0925-15NL	1-1/2"	1.50	38.00	3.86	98.00	3.43	87.00	1.57	40.00	6.89	175.00	4.76	121.00	1067
0925-20NL	2"	1.89	48.00	4.72	120.00	4.25	108.00	2.09	53.00	8.11	206.00	5.79	147.00	1917
0925-25NL	2-1/2"	2.36	60.00	5.51	140.00	4.57	116.00	2.56	65.00	10.75	273.00	7.09	180.00	3667
0925-30NL	3"	2.72	69.00	6.42	163.00	5.12	130.00	2.95	75.00	11.93	303.00	8.82	224.00	4617
0925-40NL	4"	3.94	100.00	8.86	225.00	7.01	178.00	4.06	103.00	13.11	333.00	10.94	278.00	9000

## TEMPERATURE CORRECTION FACTOR FOR PVC VALVES

As temperature increases, working pressure decreases. The optimal working pressure for PVC valves is 150 PSI @ 73°F (22°C). If the temperature increases above 73°F (22°C), use the PVC correction factor to determine working pressure. Multiply the maximum working pressure by the correction factor.

Temperature	73°F (22°C)	90°F (32°C)	100°F (38°C)	110°F (38°C)	120°F (49°C)	130°F (54°C)	140°F (60°C)
PVC Correction Factor	1.00	1.00	1.00	0.83	0.66	0.50	0.33



25 Whaley Avenue, PO Box 310, Milverton, ON CANADA N0K 1M0  
Tel: 800-561-3164

[boshart.com](http://boshart.com) ♦ [blog.boshart.com](http://blog.boshart.com)