

# 0922CTS SERIES CPVC MOLDED-IN-PLACE BALL VALVES

## SPECIFICATION:

- CPVC material conforms to ASTM D1784
- Slip connections conform to ASTM D2846
- Working Temperature Range: 32°F to 180°F (0°C to 82°C)
- Max Pressure Rating: 150 PSI @ 73°F (22°C)
- Suitable for both cold and hot water distribution systems
- One piece molded-in-place compact ball valve
- Beige CPVC body, for use with solvent weld CPVC copper tube size (CTS) pipe
- Stem seal material: EPDM o-ring
- Seat material: PTFE
- Red ABS Handle

## CERTIFICATION:

- NSF/ANSI Standard 61 Certified
- NSF/ANSI Standard 372 Certified



MATERIAL LIST	
Part Name	Material
Screw	Steel
Cap	ABS
Handle	ABS
Ball	CPVC
O-ring	EPDM
Body	CPVC
Seat	PTFE

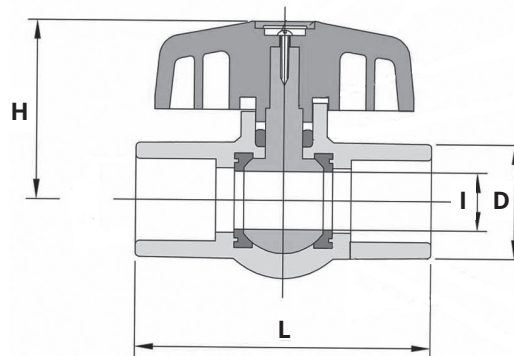

Part No.	CTS Nominal Size	I		D		H		L		Weight grams
		inches	mm	inches	mm	inches	mm	inches	mm	
0922CTS-05	1/2"	0.49	13.00	0.96	24.30	1.40	35.50	2.68	68.00	53
0922CTS-07	3/4"	0.73	19.00	1.21	30.80	1.77	45.00	3.27	83.00	87
0922CTS-10	1"	0.93	24.00	1.50	38.00	2.09	53.00	3.78	96.00	151
0922CTS-12	1-1/4"	1.02	26.00	1.77	45.00	2.40	61.00	4.15	105.50	212
0922CTS-15	1-1/2"	1.18	30.00	2.07	52.50	2.60	66.00	4.49	114.00	273
0922CTS-20	2"	1.57	40.00	2.60	66.00	3.03	77.00	5.91	150.00	502

## TEMPERATURE CORRECTION FACTOR FOR PVC / CPVC

As temperature increases, working pressure decreases. The optimal working pressure for PVC/CPVC is 150 PSI @ 73°F (22°C). If the temperature increases above 73°F (22°C), use the correction factor to determine working pressure. Multiply the maximum working pressure by the correction factor.

Temperature	73°F (22°C)	90°F (32°C)	100°F (38°C)	110°F (38°C)	120°F (49°C)	130°F (54°C)	140°F (60°C)	150°F (66°C)	160°F (71°C)	170°F (77°C)	180°F (82°C)
PVC Correction Factor	1.00	0.75	0.62	0.50	0.40	0.30	0.22	N.R.	N.R.	N.R.	N.R.
CPVC Correction Factor	1.00	0.92	0.85	0.77	0.70	0.62	0.55	0.47	0.40	0.32	0.25

N.R. - PVC Not Recommended over 140°F(60°C)



25 Whaley Avenue, PO Box 310, Milverton, ON CANADA N0K 1M0  
Tel: 800-561-3164

[boshart.com](http://boshart.com) ♦ [blog.boshart.com](http://blog.boshart.com)