

BOSHART
INDUSTRIES

FILTRATION PRODUCTS



COMMITTED TO EXCELLENCE

STANDARD FILTER HOUSING KIT

STANDARD FILTER HOUSING KIT

Application:

- Agriculture
- Drip Irrigation / Greenhouse
- Point Of Use (Under Sink / Taste & Odour)
- Recreational Vehicle
- Water Well
- Whole House Residential

Specification:

- 10" or 20" nominal lengths
- Max Pressure Rating: 125 PSI **If working pressure is consistently over 60 PSI, a pressure regulator valve is recommended to extend the life span of the bowl*
- Temperature Rating: 39-125°F (4-52°C)
- Filter head comes with pressure relief button on inlet side
- Mounting bosses molded in head for installation with mounting bracket
- Housing Kit comes complete with filter housing, O-ring (installed) plus 1 replacement O-ring, mounting bracket, hardware and wrench
- Available with 304 SS thread inserts in the head

STANDARD SLIM FILTER HOUSING KIT

Application:

- Agriculture
- Drip Irrigation / Greenhouse
- Point of Use (Under Sink / Taste & Odour)
- Water Well
- Whole House Residential

Specification:

- 10" or 20" nominal lengths
- Max Pressure Rating: 125 PSI **If working pressure is consistently over 60 PSI, a pressure regulator valve is recommended to extend the life span of the bowl*
- Temperature Rating: 39-125°F (4-52°C)
- Filter head comes with pressure relief button on inlet side
- Mounting bosses molded in head for installation with mounting bracket
- Housing Kit comes complete with filter housing, O-ring (installed) plus extra top seat and side seat O-rings, mounting bracket, hardware and wrench
- Less space needed for installation without reducing capacity
- Double O-ring design for ease of opening and closing



Accepts industry standard cartridges (not included)

STANDARD FILTER HOUSING KIT

HIGH TEMPERATURE FILTER HOUSING KIT

Application:

- Hot Water / Liquids
- Industrial / Commercial
- Photographic
- Salt Water Fisheries

Specification:

- Max Pressure Rating: 125 PSI
- Temperature Rating: 39-165°F (4-73.9°C)
- Mounting bosses molded in head for installation with mounting bracket
- Housing Kit comes complete with filter housing, O-ring (installed) plus 1 replacement O-ring, mounting bracket, hardware and wrench
- Excellent alternative to stainless and carbon housings
- Durable glass-reinforced nylon construction



EXTREME TEMPERATURE / PRESSURE SINGLE TUBE STAINLESS STEEL HOUSING KIT

Application:

- Agriculture
- Chemical
- Industrial / Commercial
- Institutional
- Point of use
- Restaurant

Specification:

- Max Pressure Rating: 300 PSI (when filter has pipe plug installed)
- Max Temperature Rating: 300°F (149°C)
- Filter head held in place by stainless steel retainer ring
- Mounting bosses molded in head for installation with mounting bracket
- Housing Kit comes complete with filter housing, mounting bracket, hardware and wrench
- For high pressure and hot water applications not suited for plastic housings



Accepts industry standard cartridges (not included)

GIANT FILTER HOUSING KIT

GIANT FILTER HOUSING KIT

Application:

- Agriculture
- Drip Irrigation / Greenhouse
- Food Processing
- Industrial / Commercial
- R.O Systems
- Spas & Hot Tub
- Water Well
- Whole House Residential

Specification:

- 10" or 20" nominal lengths
- Max Pressure Rating: 125 PSI **If working pressure is consistently over 60 PSI, a pressure regulator valve is recommended to extend the life span of the bowl*
- Temperature Rating: 39-100°F (4-38°C)
- Filter head comes with pressure relief button on inlet side
- Mounting bosses molded in head for installation with mounting bracket
- Housing Kit comes complete with filter housing, O-ring (installed) plus 1 replacement O-ring, mounting bracket, hardware and wrench
- Large capacity suitable for high flow applications



GIANT HIGH TEMPERATURE FILTER HOUSING

Application:

- Alcohols / Toluene / Xylene
- Gasoline
- Hot Water / Liquids
- Photographic
- Salt Water Fisheries
- Vegetable Oils

Specification:

- 10" or 20" nominal lengths
- Max Pressure Rating: 100 PSI
- Max Temperature Rating: 180°F (82°C)
- Mounting bosses molded in head for installation with mounting bracket
- Securely retained O-ring eliminates potential leaks due to misplacement
- Suitable for high pressure service
- Excellent alternative to stainless and carbon housings
- Durable glass-reinforced nylon construction
- Housing only



Accepts industry standard cartridges (not included)

SEDIMENT CARTRIDGE

- Micron Rating 1-50
- Standard & Giant sizes available
- 10" or 20" nominal lengths

PLEATED POLYESTER

- For a variety of uses and used in residential, commercial and industrial applications
- Non-woven polyester filter media is pleated around a polypropylene core for added strength and stability
- The pleated surface provides greater sediment and dirt-holding capacity while maintaining flow rate and reducing initial pressure drop
- Washable & reusable

SPUN POLYPROPYLENE GRADIENT DEPTH

- Standard specification meets most of the housings in the market
- For general industrial Reverse Osmosis systems, food and beverage, commercial and home Reverse Osmosis system use
- Four-layer, varied-micron rating for extended life
- NSF/ANSI Standard 42

STRING WOUND "FDA" POLYPROPYLENE

- For a wide range of filtering applications including potable water
- Manufactured from FDA grade polypropylene
- Ideal for removing very fine sediment right through to very coarse sediment, at ambient temperatures
- *NOTE: Be careful when comparing pricing - there are lower cost "INDUSTRIAL GRADE" polypropylene cartridges being sold that are not meant for filtering potable water*
- Cartridge media and core: Polypropylene
- Temperature rating: 120°F (49°C)
- NSF/ANSI Standard 42

300°F HIGH TEMPERATURE STRING WOUND COTTON

- For filtration of liquids with temperatures up to 300°F (149°C) suitable for a wide range of filtering applications including potable water
- Suitable for removing very fine sediment right through to very coarse sediment
- Cartridges are wound with bleached cotton fibres on a #304 stainless steel core
- FDA approved

300°F HIGH TEMPERATURE STRING WOUND NATURAL COTTON

- For filtration of liquids with temperatures up to 300°F (149°C) (when used in conjunction with stainless steel filter housings)
- Suitable for a wide range of filtering applications, removing very fine sediment right through to very coarse sediment
- Cartridges are wound with natural cotton fibres on a tin core
- Not FDA approved
- Not suitable for potable water



TASTE & ODOUR CARTRIDGE

- Micron Rating 0.5 - 50
- Standard & Giant sizes available
- 10" or 20" nominal lengths

CARBON BLOCK (BRIQUETTE)

- Point-of-use and Reverse Osmosis applications
- Applications such as residential, food service, commercial and industrial
- Carbon blocks replace Granular Activated Carbon and Powdered Activated Carbon filters in application where high chlorine reduction is needed
- NSF/ANSI Standard 42

CARBON BRIQUETTE 'CYST REMOVAL'

- Highly effective filtration of water for certain VOC Volatile Organic Chemicals such as Toluene and Xylene
- Effective for pesticides, chlorine, taste & odour and sediment reduction down to 0.5 micron
- Polishing filter or pre-filter in applications that require fine filtration
- Excellent at filtering Giardia and Cryptosporidium cysts from drinking water
- Potable water filtration in industrial, commercial and food service applications
- NSF/ANSI Standard 42

GRANULAR ACTIVATED CARBON

- Removes unpleasant tastes & odours to produce better tasting water
- Long-lasting and reliable performance with low pressure drop, durable physical strength and steady flow
- Reverse Osmosis systems or water dispensing systems in residential, commercial and industrial applications

POWDER ACTIVATED CARBON WRAP

- Dual-purpose cartridge to reduce bad taste & odour, chlorine taste & odour, and fine particles or sediment
- Economical cartridge with good dirt-holding capacity and high flow rates
- Constructed of carbon-impregnated cellulose media, with a polypropylene netting to provide additional strength

ICEMAKER / IN-LINE TASTE & ODOUR FILTERS

- Coconut shell and Granular Activated Carbon
- Removes unpleasant tastes & odours and sediment for cleaner, clearer, and better tasting water
- Long-lasting and reliable performance with low pressure drop, high dirt holding capacity, durable physical strength, and steady flow
- Packed carbon to eliminate shifting of the carbon
- Manufactured in compliance with NSF and FDA requirement in material, media and processing
- Easily installed on the water line to an automatic icemaker, Reverse Osmosis System or water dispensing system



FILTERS & SEPARATORS

"Spin-out" action separates heavier-than-water particles away from screen, into the collection chamber. Separation of the filtrate from the filter element compartment greatly reduces abrasion on the filter element, increasing its life span.

- Available in: 1", 1-1/2", 2"
 - Compatible with Schedule 40 & 80 PVC pipe
 - Gripper ribs on filter bowl
 - No tools required to install/remove filter bowl
 - Flush system - 1/2" MPT connection for purge valve
 - Suitable for installation on either the suction or pressure side of pump
 - Elements marked with mesh rating and replacement O-Ring for easy identification
-
- Maximum Pressure Rating: 150 PSI @ 73°F (23°C)
 - Maximum Temperature Rating: 100°F (38°C) @ 40 PSI
 - NSF/ANSI 372
 - Flow Rates:
 - 1": 1-25 GPM
 - 1-1/2": 10-50 GPM
 - 2": 18-100 GPM

APPLICATION: (WATER USE ONLY)

- Agriculture
- Industrial / Commercial
- Pre-treatment
- Whole House Residential
- Irrigation

SEDIMENT FILTER HOUSINGS & KITS INCLUDE:

- Housing
- Purge valve
- Mounting clamps and hardware
- (Filter Element in Kits only)

SEDIMENT SEPARATOR HOUSINGS & KITS INCLUDE:

- Housing
- Purge valve
- Mounting clamps and hardware
- (Separator Element in Kits only)

SEDIMENT FILTER / SEPARATOR HOUSINGS & KITS WITH MALE ADAPTERS: (FOR 1" ONLY)

- Housing
- Purge valve
- Mounting clamps and hardware
- (Filter/Separator Element in Kits only)
- 1" Spigot x 1" MPT adapters

STAINLESS STEEL MESH ELEMENTS

- Available in a wide range of mesh from 24 -1000
- 316 stainless steel

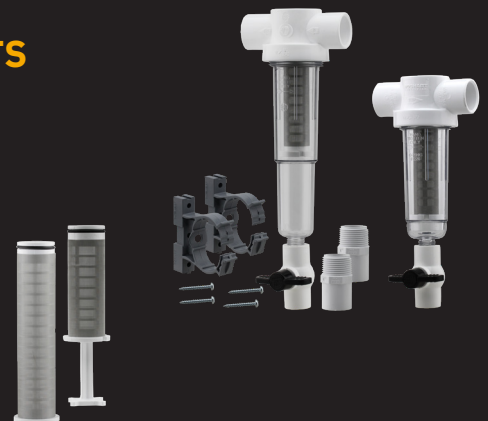

BOSHART

I N D U S T R I E S

Water Well ♦ Plumbing & Heating ♦ Industrial ♦ Sump & Sewage ♦ Irrigation ♦ Pool & Spa

25 Whaley Ave., PO Box 310
Milverton, ON Canada N0K 1M0
Telephone: 519-595-4444
Fax: 519-595-4380
Toll Free: 800-561-3164

boshart.com
Free articles at blog.boshart.com

DISTRIBUTED BY: